

STANDARD EQUIPMENT

FEATURES	SRS-W25S	SRS-W35S
Structure		
Quick Switch Hydraulic Pivoting Recovery Boom (no assembly required)	X	X
Winch		
25,000 lb High Speed Planetary Gear Winch	X	—
35,000 lb High Speed Planetary Gear Winch	—	X
5/8" Dia x 200' Long (6 x 37 IWRC RRL EIPS) Galvanized Winch Cable with Swivel Hook	X	—
5/8" Dia x 250' Long (6 x 37 IWRC RRL EIPS) Galvanized Winch Cable with Swivel Hook	—	X
Winch Level Wind System (patent pending)	X	X
Adjustable Air Controlled Winch Cable Tensioner	X	X
Driver and Passenger Side Remote Air Winch Free Spool Release with Dis-Engagement Indicator Lights	X	X
Removable Recovery Hook and Galvanized Shackle	X	X
Stabilizers		
Independent Hydraulic Stabilizer Legs	X	X
Independent Self-Stowing Flip Down Claw/Spade	X	X
Hydraulics		
Custom Hydraulic Manifold for In-Line Straight-Forward Hose Routing	X	X
Mechanical or Hydraulic Locking Features on All Functions for Improved Safety	X	X
Controls		
Wired Non-Proportional Remote Control System for All Functions	X	X
Driver and Passenger Side Plug-In Provision for Wired Remote Control	X	X
Wireless Non-Proportional Remote Control System for All Functions	X	X
Manual Override Controls	X	X
Paint		
Prime Finish	X	X
Anchor-Points		
D-Rings on Stabilizer Outer and Inner Sections (two pair total)	X	X

OPTIONAL EQUIPMENT

FEATURES	SRS-W25S	SRS-W35S
Miscellaneous		
24", 3/4 Height Driver and Passenger Side Stand Alone Tool Compartments	X	X
3/4" Dia x 200' Long (6 x 37 IWRC RRL EIPS) Galvanized Winch Cable ILO Standard Winch Cable	—	X
Snatch Block - 12-Ton, 8" Dia Sheave	X	X
Snatch Block - 12-Ton, 10" Dia Sheave	X	X
In-Cab Remote Control Transmitter Holder with Audible Warning Signal	X	X
Paint		
Custom Paint Colors Available	X	X

HEAVY-DUTY WRECKER SIDE RECOVERY SYSTEM

TACKLE THE JOB FROM EVERY ANGLE.



All equipment ratings specified are based on structural capacity only and comply with J706 Recommended Practices.

All measurements and ratings are nominal values.

All outside frame rails extending 24" behind the cab of the chassis must be free of all air tanks, battery boxes, fuel tanks, etc.

Patents Pending.

Specifications, descriptions and illustrative material contained within this literature are as accurate as known at the time of publication, but are subject to change, without notice, as a result of continuous product improvements.

Illustrations may include optional equipment and accessories and may not include all standard equipment. Always check with an authorized sales representative or call 800-926-9666 for current information.

Jerr-Dan and the Jerr-Dan logo are registered trademarks of Jerr-Dan Corporation, Greencastle, PA USA. ©Copyright Jerr-Dan Corporation, 1080 Hykes Road, Greencastle, PA 17225

800-926-9666 · 717-597-7111 · Fax: 717-593-6183 · www.jerr-dan.com

JD-0003-SRSWKR
 11/08

HEAVY-DUTY WRECKER – SIDE RECOVERY SYSTEM



GET TOUGH WORK DONE ON THE SIDE

SRS – Side Recovery System for Heavy-Duty Wreckers.

Dominate even the most challenging jobs with the Jerr-Dan® Side Recovery System for heavy-duty wreckers. It can pull from multiple angles – with the boom in pulling position, the SRS can pull from the front, side or rear, and its patent pending Pivoting Recovery Boom hydraulically pivots to allow recovery from either side.

With only 24" to mount, it can be retrofitted to an existing wrecker. And the optional tool compartment maximizes your total storage capacity. Plus, unlike others in the industry, the Independent Self-Stowing Flip Down Claw/Spade is truly self-stowing. You get greater strength and holding power with less equipment to worry about getting in the way. Do the job anywhere and everywhere. Run hard with the Jerr-Dan Side Recovery System for heavy-duty wreckers.

Six Reasons Why The SRS For Heavy-Duty Wreckers Means Business

1. With the boom locked into pulling position, the SRS is structurally capable of pulling at multiple angles – forward, sideways and rearward.
2. Reduce storage loss by utilizing the 24" space to mount – it can also be retrofitted to an existing wrecker by simply removing the 24" tunnel tool compartment.
3. The Independent Self-Stowing Flip Down Claw/Spade feature – allows for greater strength and holding power.
4. Standard hydraulic stabilizer legs allow the unit to fit varying frame heights from 40" to 45".
5. Additional tool storage capability with the optional toolbox which provides tool storage and better fit and finish.
6. The patent pending Hydraulic Pivoting Recovery Boom makes recovery from either side of the vehicle safe, easy and efficient.

FEATURES



1. Pivoting Recovery Boom
Recover from either side of the vehicle. Simply pivot the recovery boom from one side to another with the boom swing function on the remote control.



4. Stabilizing Legs
Allow for greater strength and holding power.



2. Retrofitting Capability
Only needs 24" to mount, so it can be retrofitted to an existing wrecker by simply removing the tunnel tool compartment.



5. 25,000 lb / 35,000 lb High Speed, Planetary Winch
Choice of 25,000 or 35,000 lb capacity planetary winches for maximum recovery potential.



3. Independent Self-Stowing Flip Down Claw/Spade
The only SRS for wreckers in the industry with claw and spade self-stowing capability.



6. Wired and Wireless Remote Controls
Standard for all functions and allows operators to maintain a safe distance during recovery.

RECOMMENDED CHASSIS REQUIREMENTS

SRS-W25S / SRS-W35S

Minimum Frame RBM (both rails combined)

SRS-W25S	3,200,000 in-lbs
SRS-W35S	4,200,000 in-lbs

Minimum Front GAWR

25-Ton, 30-Ton & 35-Ton Wreckers	16,000 lbs
50-Ton & 60-Ton Wreckers	18,000 lbs

Frame Height Range	40"-45"
Frame Width Range	34"-35"
Additional Cab to Axle	24"

SPECIFICATIONS

SRS-W25S

Structural Capacity	35,000 lbs
Winch Line Pull (first layer)	25,000 lbs
Wire Rope	5/8" dia x 200 ft
Weight	4,500 lbs

SRS-W35S

Structural Capacity	35,000 lbs
Winch Line Pull (first layer)	35,000 lbs
Wire Rope	5/8" dia x 250 ft
Weight	4,500 lbs

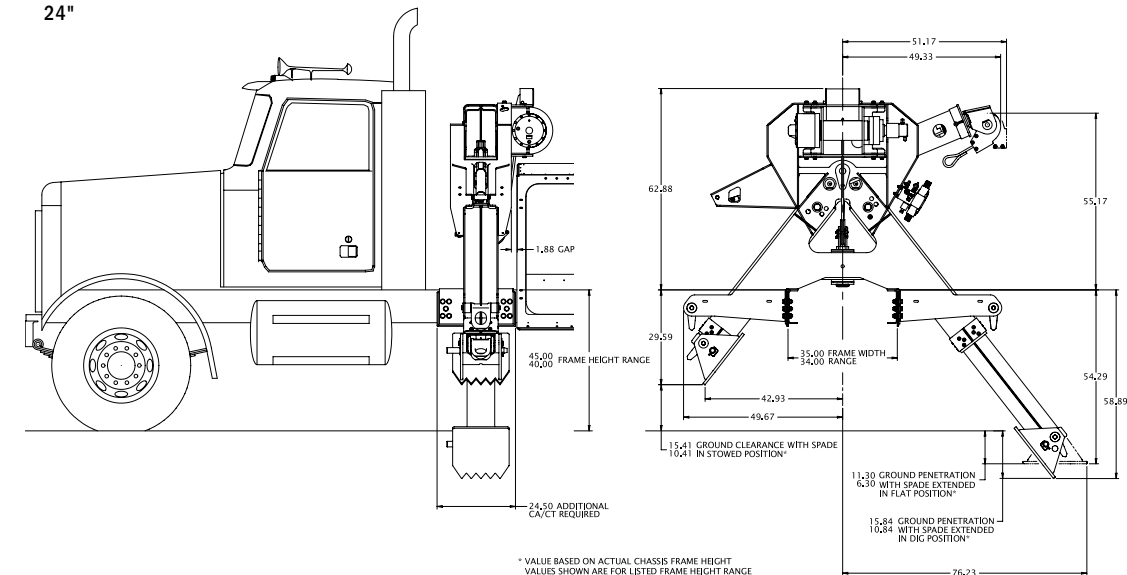

* VALUE BASED ON ACTUAL CHASSIS FRAME HEIGHT
VALUES SHOWN ARE FOR LISTED FRAME HEIGHT RANGE